

Zinc Oxide Surge Arrester PEXLIM Q-Y

Protection of switchgear, transformers and other equipment in high voltage systems against atmospheric and switching overvoltages.

- in areas with high lightning intensity and high energy requirements.
- where grounding or shielding conditions are poor or incomplete.

Superior where low weight, reduced clearances, flexible mounting, non-fragility and additional personnel safety is required.

Major component in PEXLINK™ concept for transmission line protection.



Other data can be ordered on request. Please contact your local sales representative.

Brief performance data

Arrester classification as per IEC 60099-4 Ed 3.0	Station; SM
Arrester classification as per IEEE Std C62.11-2012	Station
System voltages (U_s)	52 - 420 kV
Rated voltages (U_r)	42 - 396 kV
Nominal discharge current (IEC)	10 kA _{peak}
Lightning impulse classifying current (ANSI/IEEE)	10 kA _{peak}
Charge, energy and current withstand:	
Repetitive charge transfer rating, Q_{rs} (IEC)	2.0 C
Thermal energy rating, W_{th} (IEC)	8 kJ/kV (U_r)
Single impulse energy capability (2 ms to 4 ms impulse)	4.5 kJ/kV (U_r)
Discharge current withstand strength:	
High current 4/10 μ s	100 kA _{peak}
Low current 2000 μ s, (based on Q_{rs})	1000 A _{peak}
Energy class as per IEEE standard (switching surge energy rating)	E
Single-impulse withstand rating as per IEEE standard	2.2 C
Repetitive charge transfer test value - sample tests on all manufactured block batches	2.7 C
Short-circuit/Pressure relief capability	65 kA _{rms(sym)}
Mechanical strength:	
Specified long-term load (SLL)	2500 Nm
Specified short-term load (SSL)	4000 Nm
Service conditions:	
Ambient temperature	-50 °C to +45 °C
Design altitude	max. 1000 m
Frequency	15 - 62 Hz
Line discharge class (as per IEC60099-4, Ed. 2.2)	Class 3

Further data according to the IEEE standard can be supplied on request



PEXLIM Q-Y

Guaranteed protective data 24 - 145 kV

Max. system voltage U_s	Rated voltage U_r	Max. continuous operating voltage ¹⁾		TOV capability ²⁾		Max. residual voltage with current wave						
		as per IEC	as per ANSI/IEEE	1 s	10 s	30/60 μ s			8/20 μ s			
		U_c	MCOV			0.5 kA	1 kA	2 kA	5 kA	10 kA	20 kA	40 kA
kV _{rms}	kV _{rms}	kV _{rms}	kV _{rms}	kV _{rms}	kV _{rms}	kV _{peak}	kV _{peak}	kV _{peak}	kV _{peak}	kV _{peak}	kV _{peak}	kV _{peak}
24 ³⁾	24	19.2	19.5	26.4	24.9	46.1	47.6	49.5	53.6	56.4	62.1	69.4
36 ³⁾	30	24.0	24.4	33.0	31.2	57.6	59.5	61.8	67.0	70.5	77.6	86.8
	33	26.4	26.7	36.3	34.3	63.4	65.4	68.0	73.7	77.6	85.4	95.4
	36	28.8	29.0	39.6	37.4	69.2	71.4	74.2	80.4	84.6	93.1	105
52	42	34	34.0	46.2	43.7	80.7	83.3	86.5	93.8	98.7	109	122
	48	38	39.0	52.8	49.9	92.2	95.1	98.9	108	113	125	139
	51	41	41.3	56.1	53.0	98.0	102	105	114	120	132	148
	54	43	43.0	59.4	56.2	104	107	112	121	127	140	157
	60	48	48.0	66.0	62.4	116	119	124	134	141	156	174
	66	53	53.4	72.6	68.7	127	131	136	148	156	171	191
	72	58	58.0	79.2	74.9	139	143	149	161	170	187	209
72	54	43	43.0	59.4	56.2	104	107	112	121	127	140	157
	60	48	48.0	66.0	62.4	116	119	124	134	141	156	174
	66	53	53.4	72.6	68.7	127	131	136	148	156	171	191
	72	58	58.0	79.2	74.9	139	143	149	161	170	187	209
	75	60	60.7	82.5	78.0	144	149	155	168	177	194	217
	78	62	63.1	85.8	81.1	150	155	161	175	184	202	226
	81	65	65.6	89.1	84.3	156	161	167	181	191	210	235
	84	67	68.0	92.4	87.4	162	167	173	188	198	218	243
100	75	60	60.7	82.5	78.0	144	149	155	168	177	194	217
	78	62	63.1	85.8	81.1	150	155	161	175	184	202	226
	81	65	65.6	89.1	84.3	156	161	167	181	191	210	235
	84	67	68.0	92.4	87.4	162	167	173	188	198	218	243
	90	72	72.0	99.0	93.6	173	179	186	201	212	233	261
	96	77	77.0	105	99.9	185	191	198	215	226	249	278
123	90	72	72.0	99.0	93.6	173	179	186	201	212	233	261
	96	77	77.0	105	99.9	185	191	198	215	226	249	278
	102	78	82.6	112	106	196	203	210	228	240	264	295
	108	78	84.0	118	112	208	214	223	242	254	280	313
	120	78	98.0	132	124	231	238	248	268	282	311	347
	129	78	104	141	134	248	256	266	288	304	334	373
	132	78	106	145	137	254	262	272	295	311	342	382
	138	78	111	151	143	265	274	285	309	325	357	399
	144	78	115	158	149	277	286	297	322	339	373	417
	150	78	121	165	156	288	298	309	335	353	388	434
145	108	86	86.0	118	112	208	214	223	242	254	280	313
	114	91	92.3	125	118	219	226	235	255	268	295	330
	120	92	98.0	132	124	231	238	248	268	282	311	347
	132	92	106	145	137	254	262	272	295	311	342	382

1) The continuous operating voltages U_c (as per IEC) and MCOV (as per IEEE) differ only due to deviations in type test procedures.

U_c has to be considered only when the actual system voltage is higher than the tabulated.

Any arrester with U_c higher than or equal to the actual system voltage divided by $\sqrt{3}$ can be selected.

2) With prior duty equal to the thermal energy rating of 8 kJ/kV (U_r).

3) Arresters for system voltages 36 kV or below can be supplied, on request, when the order also includes arresters for higher system voltages.

Arresters with lower or higher rated voltages may be available on request for special applications.

PEXLIM Q-Y

Guaranteed protective data 145 - 420 kV

Max. system voltage	Rated voltage	Max. continuous operating voltage ¹⁾		TOV capability ²⁾		Max. residual voltage with current wave						
		as per IEC	as per ANSI/IEEE	1 s	10 s	30/60 µs			8/20 µs			
						U _c	MCOV	0.5 kA	1 kA	2 kA	5 kA	10 kA
U _m	U _r	U _c	MCOV	1 s	10 s	0.5 kA	1 kA	2 kA	5 kA	10 kA	20 kA	40 kA
kV _{rms}	kV _{rms}	kV _{rms}	kV _{rms}	kV _{rms}	kV _{rms}	kV _{peak}	kV _{peak}	kV _{peak}	kV _{peak}	kV _{peak}	kV _{peak}	kV _{peak}
145	138	92	111	151	143	265	274	285	309	325	357	399
	144	92	115	158	149	277	286	297	322	339	373	417
	150	92	121	165	156	288	298	309	335	353	388	434
	162	92	131	178	168	312	321	334	362	381	419	469
	168	92	131	184	174	323	333	346	376	395	435	486
	180	92	144	198	187	346	357	371	402	423	466	521
170	132	106	106	145	137	254	262	272	295	311	342	382
	144	108	115	158	149	277	286	297	322	339	373	417
	150	108	121	165	156	288	298	309	335	353	388	434
	162	108	131	178	168	312	321	334	362	381	419	469
	168	108	131	184	174	323	333	346	376	395	435	486
	180	108	144	198	187	346	357	371	402	423	466	521
245	192	108	152	211	199	369	381	396	429	452	497	555
	180	144	144	198	187	346	357	371	402	423	466	521
	192	154	154	211	199	369	381	396	429	452	497	555
	198	156	160	217	206	381	393	408	443	466	512	573
	210	156	170	231	218	404	417	433	469	494	543	608
	216	156	175	237	224	415	428	445	483	508	559	625
	219	156	177	240	227	421	434	451	489	515	567	634
	222	156	179	244	231	427	440	458	496	522	574	642
300	228	156	180	250	237	438	452	470	510	536	590	660
	216	173	175	237	224	415	428	445	483	508	559	625
	240	191	191	264	249	461	476	495	536	564	621	694
	258	191	209	283	268	496	512	532	576	607	667	746
	264	191	212	290	274	507	523	544	590	621	683	764
362	276	191	220	303	287	530	547	569	617	649	714	798
	258	206	209	283	268	496	512	532	576	607	667	746
	264	211	212	290	274	507	523	544	590	621	683	764
	276	221	221	303	287	530	547	569	617	649	714	798
420	288	230	230	316	299	553	571	593	643	677	745	833
	330	264	267	363	343	634	654	680	737	776	854	954
	336	267	272	369	349	646	666	692	751	790	869	972
	342	267	277	376	356	657	678	705	764	804	885	989
	360	267	291	396	374	692	714	742	804	846	931	1046
	372	267	301	409	387	715	737	766	831	875	962	1080
	378	267	306	415	393	726	749	779	844	889	978	1098
	381	267	308	419	396	732	755	785	851	896	985	1106
	390	267	315	429	405	749	773	803	871	917	1013	1132
	396	267	318	435	412	761	785	816	885	931	1029	1150

1) The continuous operating voltages U_c (as per IEC) and MCOV (as per IEEE) differ only due to deviations in type test procedures.

U_c has to be considered only when the actual system voltage is higher than the tabulated.

Any arrester with U_c higher than or equal to the actual system voltage divided by $\sqrt{3}$ can be selected.

2) With prior duty equal to the thermal energy rating of 8 kJ/kV (U_r).

Arresters with lower or higher rated voltages may be available on request for special applications.

PEXLIM Q-Y

Technical data for housings

Max. system voltage	Rated voltage	Housing	Creepage distance	External insulation *)				Dimensions					
				1.2/50 μ s dry	50 Hz wet (60s)	60 Hz wet (10s)	250/2500 μ s wet	Mass	A _{max}	B	C	D	Fig.
U _m	U _r							kg	mm	mm	mm	mm	
kV _{rms}	kV _{rms}		mm	kV _{peak}	kV _{rms}	kV _{rms}	kV _{peak}						
24	24	YV024	1363	269	120	120	223	18	483	-	-	-	1
36	30-36	YV036	1363	269	120	120	223	18	483	-	-	-	1
52	42-72	YV052	2889	390	200	200	333	28	743	-	-	-	2
72	54-84	YV072	2889	390	200	200	333	28	743	-	-	-	2
100	75-84	YH100	2889	390	200	200	333	28	743	-	-	-	2
	75-96	YV100	3740	499	238	238	409	35	956	-	-	-	2
123	90-120	YH123	3740	499	238	238	409	35	956	-	-	-	2
	90-150	YV123	4549	580	295	295	461	42	1127	-	-	-	2
145	108-120	YH145	3740	499	238	238	409	34	956	-	-	-	2
	108-150	YV145	4549	580	295	295	461	42	1147	-	-	-	3
	162-168	YV145	5778	780	400	400	666	49	1431	-	-	-	4
	180	YV145	6629	889	438	438	742	57	1644	-	-	-	4
170	132-150	YH170	4549	580	295	295	461	40	1147	-	-	-	3
	132-168	YV170	5778	780	400	400	666	50	1431	-	-	-	4
	180-192	YV170	6629	889	438	438	742	57	1644	-	-	-	4
245	180-198	YH245	6629	889	438	438	742	57	1627	400	-	160	5
	210-228	YH245	7438	970	495	495	794	63	1798	400	-	160	5
	180-198	YV245	8289	1079	533	533	870	76	2028	800	-	400	6
	210-228	YV245	8289	1079	533	533	870	76	2028	600	-	300	5
300	216	YH300	8289	1079	533	533	870	74	2028	800	-	400	6
	240	YH300	8289	1079	533	533	870	73	2028	800	-	200	6
	258-264	YH300	8289	1079	533	533	870	74	2028	800	-	200	7
	276	YH300	9098	1160	590	590	922	81	2306	800	-	200	7
	216-240	YV300	9518	1279	638	638	1075	90	2419	900	800	400	10
	258-276	YV300	9518	1279	638	638	1075	90	2419	900	-	300	9
362	258-276	YH362	9098	1160	590	590	922	91	2306	1400	1000	600	8
	288	YH362	9098	1160	590	590	922	83	2306	900	-	300	7
	258-288	YV362	11220	1497	714	714	1227	111	2845	1400	1000	600	10
420	330-360	YH420	11178	1469	733	733	1203	104	2803	1400	-	500	9
	330-396	YV420	13647	1740	885	885	1383	109	3358	1400	1000	600	10

Neutral-ground arresters

52	30-36	YN052	1363	269	120	120	223	18	483	-	-	-	1
72	42-54	YN072	2889	390	200	200	333	28	743	-	-	-	2
100	60	YN100	2889	390	200	200	333	28	743	-	-	-	2
123	72-84	YN123	2889	390	200	200	333	27	743	-	-	-	2
	90-120	YN123	3740	499	238	238	409	35	956	-	-	-	2
145	84	YN145	2889	390	200	200	333	27	743	-	-	-	2
	90-120	YN145	3740	499	238	238	409	35	956	-	-	-	2
170	96-120	YN170	3740	499	238	238	409	34	956	-	-	-	2
	132	YN170	4549	580	295	295	461	40	1127	-	-	-	2
245	108-120	YN245	3740	499	238	238	409	34	956	-	-	-	2
	132-144	YN245	4549	580	295	295	461	40	1127	-	-	-	2

*) Sum of withstand voltages for empty units of arrester.

PEXLIM Q-Y

Technical data for housings

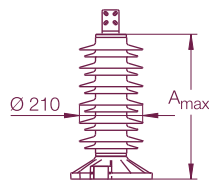

Figure 1

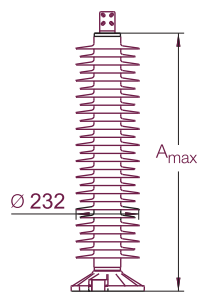

Figure 2

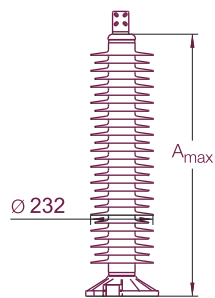

Figure 3

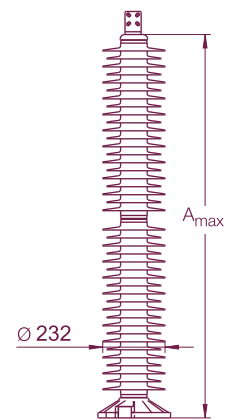

Figure 4

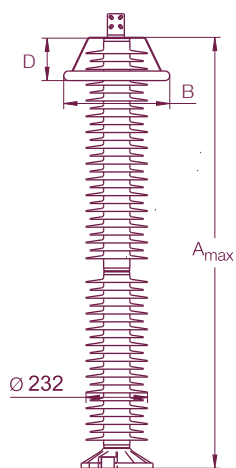

Figure 5

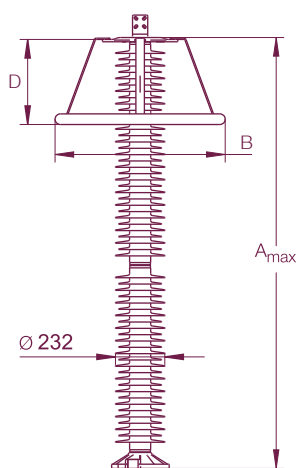

Figure 6

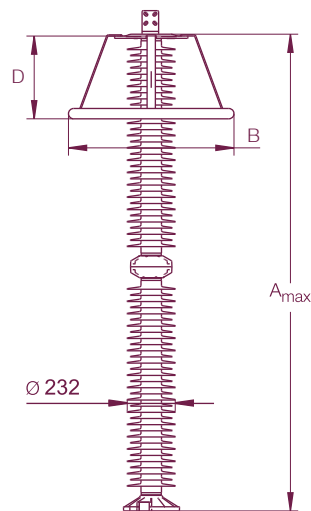

Figure 7

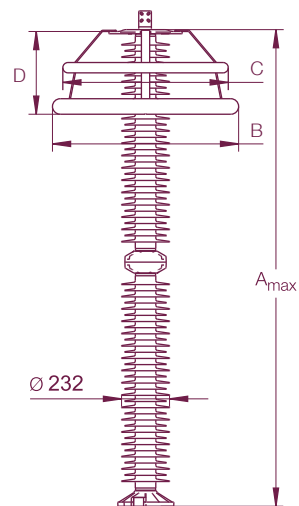

Figure 8

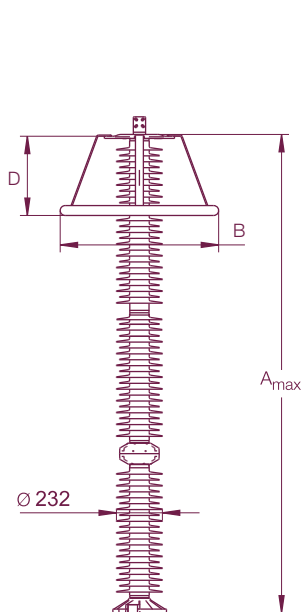

Figure 9

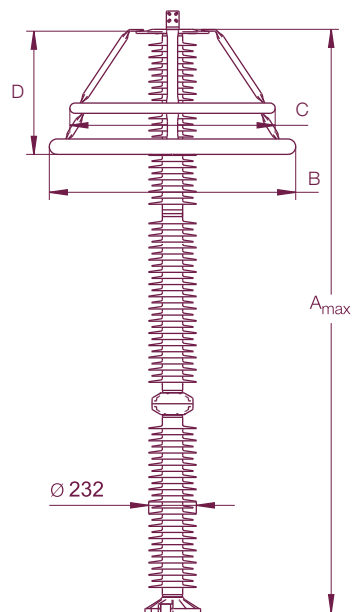
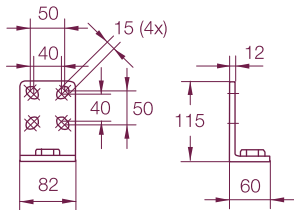

Figure 10

PEXLIM Q-Y

Accessories

Line terminals



1HSA410 000-L
Aluminium

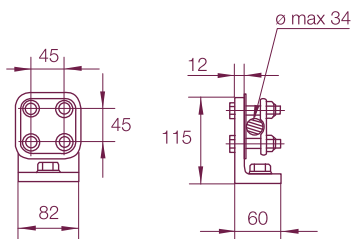

1HSA410 000-M
Aluminium flag with other
items in stainless steel

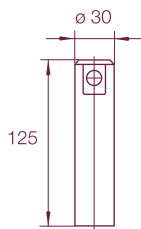

1HSA410 000-N
Aluminium

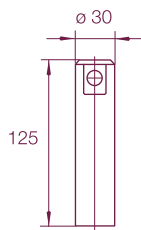

1HSA410 000-P
Stainless steel

Earth terminals

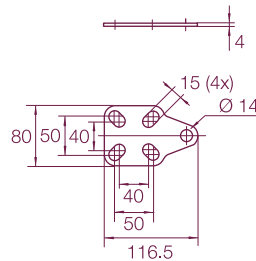

1HSA420 000-A
Stainless steel

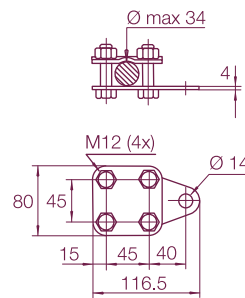

1HSA420 000-B
Stainless steel

Drilling plans

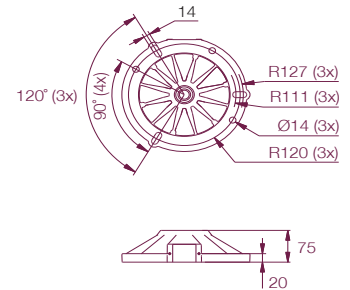

NOTE! Alternative drilling plan
3 slotted holes (120 °), n14 at R111-127

Without insulating base
Aluminium

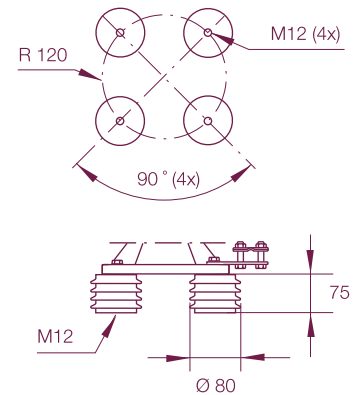

Insulating base
1HSA430 000-A
Epoxy resin

M12 bolts for connection to structure
are not supplied by ABB. Required
threaded grip length is 15-20 mm.

PEXLIM Q-Y

Shipping data

Rated voltage U_r kV _{rms}	Housing	Number of arresters per crate					
		One Volume m ³	Gross kg	Three Volume m ³	Gross kg	Six Volume m ³	Gross kg
24	YV024	0.14	28	0.51	74	0.90	128
30-36	YV036	0.14	28	0.51	74	0.90	128
42-72	YV052	0.14	38	0.51	104	0.90	188
54-84	YV072	0.14	37	0.51	104	0.90	188
75-84	YH100	0.14	37	0.51	101	0.90	182
75-96	YV100	0.20	48	0.69	130	1.22	235
90-120	YH123	0.20	48	0.69	130	1.22	235
90-150	YV123	0.20	55	0.69	151	1.22	277
108-120	YH145	0.20	55	0.69	127	1.22	229
108-150	YV145	0.20	55	0.69	151	1.22	277
162-168	YV145	0.27	64	0.87	177	1.51	324
180	YV145	0.27	72	0.87	201	1.51	372
132-150	YH170	0.20	53	0.69	145	1.22	265
132-168	YV170	0.27	65	0.87	180	1.51	330
180-192	YV170	0.27	70	0.87	225	1.51	420
180-198	YH245	0.87	92	0.87	206	1.51	372
210-228	YH245	1.06	95	1.06	224	1.87	413
180-198	YV245	1.06	111	1.06	263	1.87	491
210-228	YV245	1.06	108	1.06	254	1.87	473
216-240	YH300	1.06	109	1.06	257	1.87	479
258-264	YH300	0.70	100	1.22	250	-	-
276	YH300	0.70	106	1.22	268	-	-
216-240	YV300	1.31	165	1.97	348	-	-
258-276	YV300	1.31	163	1.97	336	-	-
258-276	YH362	1.48	191	2.22	383	-	-
288	YH362	1.14	155	1.66	340	-	-
258-288	YV362	1.84	225	2.87	453	-	-
330-360	YH420	1.65	210	2.53	424	-	-
330-396	YV420	2.0	252	3.16	552	-	-

Neutral-ground arresters

30-36	YN052	0.14	28	0.51	74	0.90	128
42-54	YN072	0.14	38	0.51	104	0.90	188
60	YN100	0.14	38	0.51	104	0.90	188
72-84	YN123	0.14	37	0.51	101	0.90	182
90-120	YN123	0.20	48	0.69	130	1.22	245
84	YN145	0.14	37	0.51	101	0.90	182
90-120	YN145	0.20	48	0.69	130	1.22	245
96-120	YN170	0.20	47	0.69	127	1.22	229
132	YN170	0.20	53	0.69	145	1.22	265
108-120	YN245	0.20	47	0.69	127	1.22	229
132-144	YN245	0.20	53	0.69	145	1.22	265

Each crate contains a certain number of arrester units and accessories for assembly and erection. A packing list is attached externally on each crate.

Each separate crate is numbered and the numbers of all crates and their contents are listed in the shipping specifica-

tion. ABB reserves the right to pack arresters in the most effective/economic combination. Alternate or non-standard crates may involve additional charges.



The table above is to be seen as an approximation and specific data for deliveries may differ from the values given.